

FIBERFIX SYSTEM FIBER LAYERS LINING

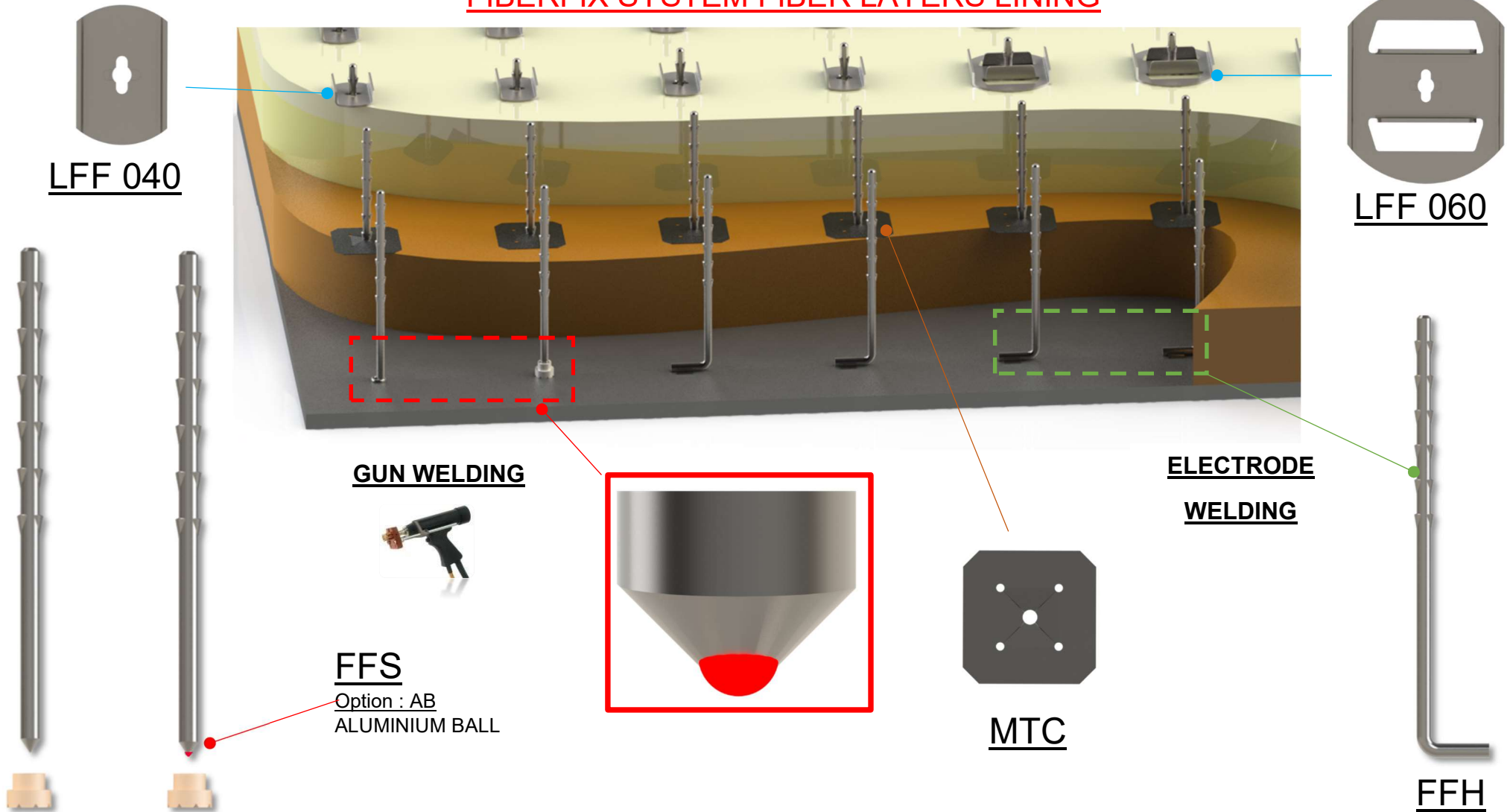

LFF 040

LFF 060

GUN WELDING



ELECTRODE WELDING

FFS

Option : AB
ALUMINIUM BALL

MTC

FFH

www.anchorsforrefractory.com
contact@anchorsforrefractory.com



Tél : + 33 3 66 50 00 33 / +33 7 85 06 29 49
PA Vallée de l'Escaut - rue de la crête - 59264 ONNAING-France

These informations are general informative indications. Many particular conditions of use and exceptions exist in industrial applications, many parameters can influence the technical choices. The informations mentioned in this technical data sheet, in particular regarding the features and the performances of the products, is provided for guidance purposes only and is liable to change depending of the conditions of use and environment. Information mentioned can be modified without notice. The company ANCHORS will in no circumstances be held liable for the consequences of any improper use. If you want some suggestions from us, applicable for your specific application and/or environment, please contact us.

FIBERFIX SYSTEM

FFS - 200 - 304
TYPE LENGTH L ALLOY



FFH - 200 - 310
TYPE LENGTH L ALLOY



FFT - 200 - 310
TYPE LENGTH L ALLOY

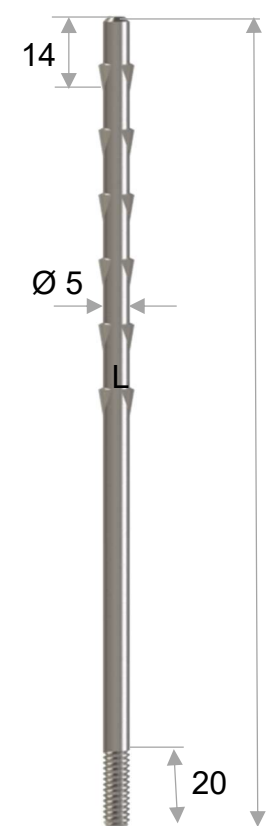

FERRULES

FER 052 for D=+/- 5.35 mm

Options : FFS

FFS AB -200-310
Aluminium Ball
Gun welding
See page D2-05



www.anchorsforrefractory.com
contact@anchorsforrefractory.com



Tél : + 33 3 66 50 00 33 / +33 7 85 06 29 49

PA Vallée de l'Escaut - rue de la crête - 59264 ONNAING-France

These informations are general informative indications. Many particular conditions of use and exceptions exist in industrial applications, many parameters can influence the technical choices. The informations mentioned in this technical data sheet, in particular regarding the features and the performances of the products, is provided for guidance purposes only and is liable to change depending of the conditions of use and environment. Information mentioned can be modified without notice. The company ANCHORS will in no circumstances be held liable for the consequences of any improper use. If you want some suggestions from us, applicable for your specific application and/or environment, please contact us.

LFF - 040 - 310
TYPE THICKNESS ALLOY



LFF - 060 - 310
TYPE THICKNESS ALLOY



MTC - 045 - 000
TYPE Ø ALLOY

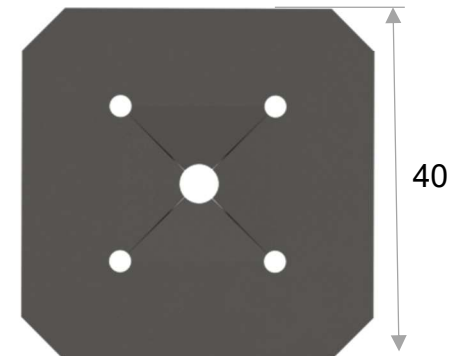
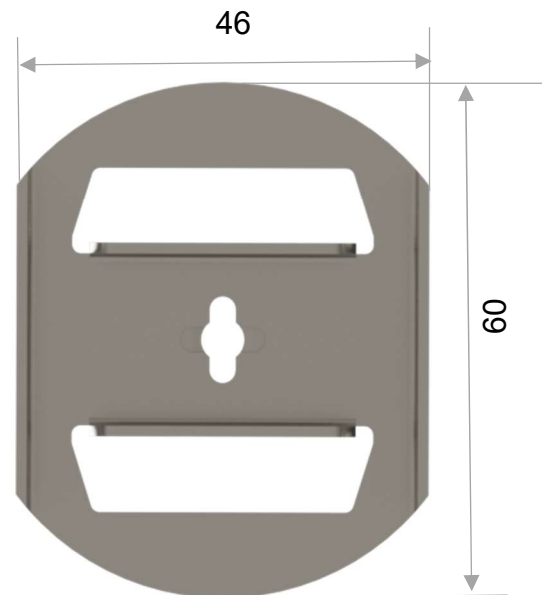
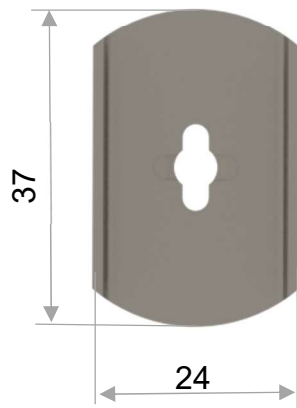

FIXING CLIPS HOT FACE

Mounting clip
in Carbon Steel or AISI 301
for fixing intermediate blankets in
a layer construction
NOT SUITABLE HOT FACE

www.anchorsforrefractory.com
contact@anchorsforrefractory.com



Tél : + 33 3 66 50 00 33 / +33 7 85 06 29 49
PA Vallée de l'Escaut - rue de la crête - 59264 ONNAING-France

These informations are general informative indications. Many particular conditions of use and exceptions exist in industrial applications, many parameters can influence the technical choices. The informations mentioned in this technical data sheet, in particular regarding the features and the performances of the products, is provided for guidance purposes only and is liable to change depending of the conditions of use and environment. Information mentioned can be modified without notice. The company ANCHORS will in no circumstances be held liable for the consequences of any improper use. If you want some suggestions from us, applicable for your specific application and/or environment, please contact us.